

ScanTrailer™ 100100V-2is



Feature Highlights

- Mobile, flexible system
- Incorporates HI-SCAN 100100V-2is
- Heat insulated body
- Trailer for public road (option)
- Integrated power generator (option)
- Easy loading by motorized conveyor
- Penetration up to 37 mm steel (typical)
- Film safe up to ISO 1600 / 33 DIN

ScanTrailer is a mobile X-ray inspection system using a non-motorized trailer for public roads with an especially manufactured body. A non-motorized trailer for public roads is available as an option. The X-ray inspection system HI-SCAN 100100V-2is is integrated.

The ScanTrailer has been designed for places where luggage, freight or mail is loaded or unloaded and has to be checked for customs or security purposes.

The system operates with AC mains. An integrated power generator (option) serves to supply the electrical devices independent of a mains source.

Fast and easy loading and unloading of items to be inspected is established by a powerful motorized conveyor (input side) and a heavy duty roller conveyor (output side).

ScanTrailer incorporates the X-ray inspection system HI-SCAN 100100V-2is with a tunnel opening of 1010 mm (width) by 1010 mm (height).

The powerful X-ray generator (160 kVcp) in combination with the sensitive detector system and the enhanced image processing system provide a penetration of up to 30 mm steel (typical). Solid wires up to 0.09 mm Ø (AWG 39) are detectable.

HI-SCAN 100100V-2is General Specifications (refer to sheet 95592188 for more information)

Tunnel dimensions	1010 (W) x 1010 (H) [mm] • 39.7" (W) x 39.7" (H)
Max. object size	1000 (W) x 1000 (H) [mm] • 39.4" (W) x 39.4" (H)
Conveyor height ¹⁾	approx. 620 mm [24.4"]
Conveyor speed	approx. 0.20 [m/s]
Max. conveyor load even distributed over the whole conveyor	220 kg (485 lbs)
Conveyor system	integrated feed-in conveyor (length approx. 1.7 m [67"] HD discharge roller conveyor (length approx. 1.7 m [67"] fold down in horizontal position for operation
Resolution (wire detectability) ²⁾	standard: 39 AWG (0.09 mm) • typical: 40 AWG (0.08 mm)
Penetration (steel) ²⁾	standard (view A): 35 mm • typical (view A): 37 mm standard (view B): 35 mm • typical (view B): 37 mm
Film safety	guaranteed up to ISO 1600 [33 DIN]
Duty cycle	100 %, no warm-up procedure required

ScanTrailer 100100V-2is General Specifications

Trailer	3500 kg [7716.2 lbs] permitted total weight
Body	thermo body in sandwich technique
Control	control desk
Safety	indicator X-ray on; emergency stop system
Power supply ⁵⁾	external power supply 220 VAC - 240 VAC +10% / -15%; 50 Hz or 60 Hz ± 3 Hz; power cable for external power supply; power distribution
Additional features	illumination accessories
Options	motorized discharging conveyor; video system for (dis-) charging area; 19" monitor ⁵⁾ ; intercom system; public road configuration; power generator ⁵⁾

Trailer General Specifications

Axle	suspended twin wheel axle
Max. speed	80 km/h (50 mph)
Brake	operation brake overrunning type; hand operated parking brake
Steering	rim steering
Tow bar	tow bar with DIN tow eye
Accessories	one spare wheel

¹⁾ from vehicle floor / approx. values

²⁾ Conds.: steel step wedge, CU wires, belt speed 0.24 m/s

⁴⁾ extended temperature range on request

⁵⁾ different values / types optional

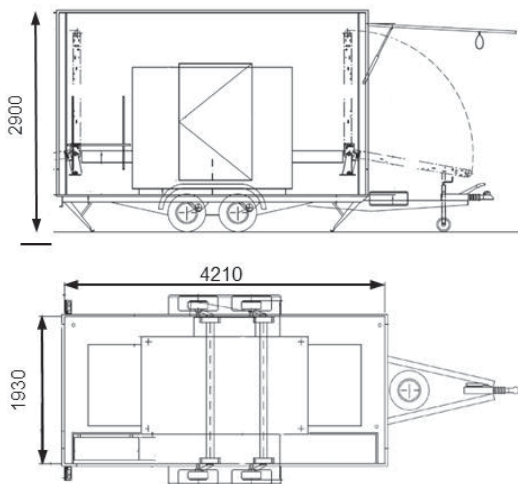

For product information, sales or service, please go to www.smithsdetection.com/locations

Smiths Detection Germany GmbH, Im Herzen 4, 65205 Wiesbaden, Germany
Modifications reserved. 95595510 13/04/2022 © Smiths Detection Group Ltd. - In some cases, the figures contain options
ScanTrailer is a trademark of Smiths Detection Group Ltd.