

HI-SCAN™ 6040 CTiX

CT TECHNOLOGY AT THE CHECKPOINT

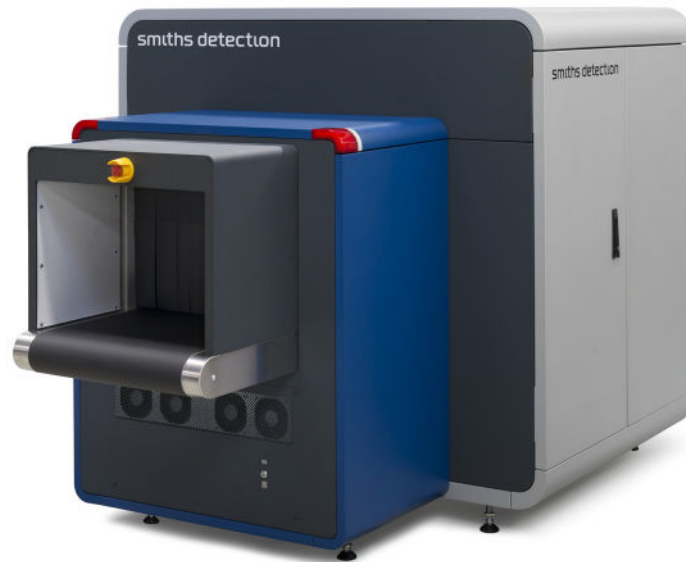

Feature Highlights

- Automatic explosives detection and object recognition
- Fast 0.2m/s belt speed
- Low energy consumption
- Minimal noise/zero vibration
- Highest certifications/approvals

Certifications/ Approvals:

- Europe: ECAC EDS CB C3 approved**
- USA: TSA CPSS certified (Detection Standard APSS v6.2 level 1)**
- France: STAC approved**
- Italy: ENAC approved**
- Israel: IPMO approved**

Leveraging the latest Computed Tomography (CT) technology, the HI-SCAN 6040 CTiX passenger checkpoint scanner delivers increased productivity; lower operating costs; and the highest standards of security (ECAC and STAC EDS CB3 approval as well as TSA APSS 6.2 Level 1 certification).

The overall screening process is streamlined to improve security outcome, operational efficiency and the customer experience. Eliminating the need to remove electronic devices, liquids and gels from hand luggage reduces the number of trays and speeds up divesting. A 0.2m/s conveyor belt drives throughput and high quality and 3D X-ray images help operators to make fast and accurate decisions. The HI-SCAN 6040 CTiX user interface received the 2020 Red Dot award for fast and intuitive 3D image evaluation.

In addition to automatic explosives detection algorithms, the optional iCMORE automated object recognition software enables the HI-SCAN 6040 CTiX to detect an expanding list of prohibited items including guns and knives.

The latest data security features and controls ensure customer data and assets are well protected from cyber-attacks. They include operating system hardening, a host-based firewall and strong encryption algorithms. System integrity is constantly monitored for unauthorised changes.

The HI-SCAN 6040 CTiX is easily integrated into existing Smiths Detection and third party checkpoints. It has a single phase 120/230V power supply for installation in Europe, the USA, APAC region and around the world. At 2.8 kVA, energy consumption is reduced by 5%-20% compared to other scanners in this class. Noise levels under 60dB(A) plus zero vibration help maintain a more pleasant checkpoint environment.

Technical Data

Dimensions • weight	3300 (L) x 1660 (W) x 1624 (H) [mm] • approx. 2450 kg 129.9" (L) x 65.4" (W) x 63.9" (H) • approx. 5401 lbs
Operating temperature	0° - 40°C
Power supply CT	single phase 230 VAC +10% / -15% • 50 Hz / 60 Hz ± 3 Hz, 16 A single phase 120 VAC +10% / -15% • 50 Hz / 60 Hz ± 3 Hz, 30 A
Tunnel dimensions	620 (W) x 420 (H) [mm] • 24.4" (W) x 16.5" (H)
Conveyor speed	0.2 [m/s]
Sound pressure	< 60 dB(A)
Max. conveyor load even distributed	160 kg (352 lbs)
External dose rate	≤ 1 µSv/h (0,1 mrem)
Humidity	10% - 90% (not condensing)

Additional Features

Operator Training Software ¹⁾
Full Integration into Checkpoint.Evo^{plus}
3D TIP ¹⁾
Compatibility with aTiX Checkpoints

Optional Features

iCMORE Weapons

¹⁾ Requires Heimann Management Server HMS or integration with Checkpoint.Evo^{plus}

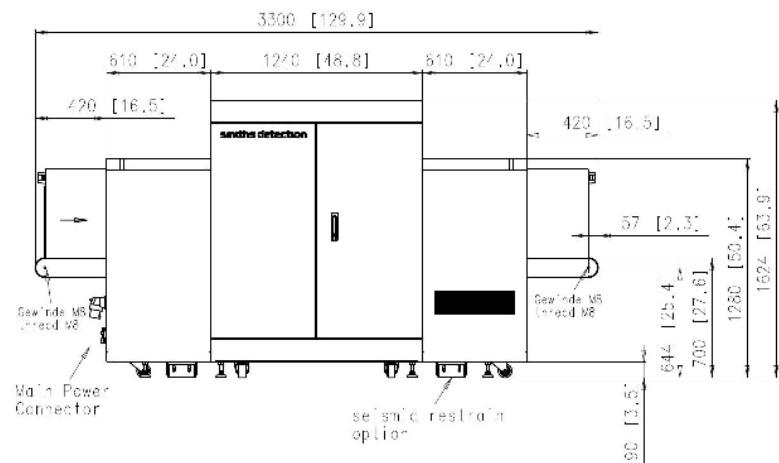
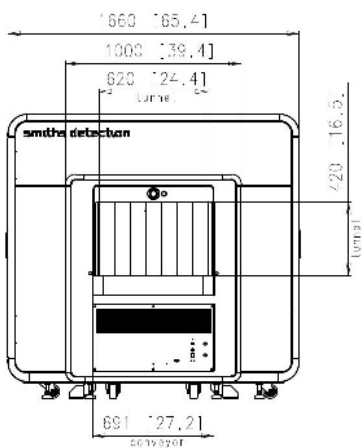

red dot winner 2020
interface design

For product information, sales or service, please go to www.smithsdetection.com/locations

Smiths Detection Germany GmbH, Im Herzen 4, 65205 Wiesbaden, Germany
Modifications reserved. 95595955 09/11/2021 © Smiths Detection Group Ltd. - In some cases, the figures contain options
HI-SCAN is a trademark of Smiths Detection Group Ltd.

smiths detection