

EMIS-MAIL

IED Detector for Letter & Small Parcel Inspection

The EMIS-MAIL is designed to detect a wide variety of metal threat items including detonators, batteries, trigger circuits and other metal components of parcel bombs without false alarms for non-threat items such as metal staples, paper clips and metal binding spirals.

The EMIS-MAIL is very easy to use and provides a fast and automatic alarm/no alarm signal confirmation per each inspected package. Its compact, ergonomic design along with the electric and built-in NiMH rechargeable battery power supply allows for independent operation in a variety of locations. An optional embedded radioactive detector is also available for radioactive material threat detection.

The EMIS-MAIL is uniquely qualified to operate in a prison or correctional facility environment with specific settings available for prison parcel inspection. Along with meeting the strictest safety and



Key features

- Ease of Installation and Setup
- Ease and Speed of System Use with Limited Screener Training Required
- Automatic Inspection of Parcels and Letters up to 18" Wide and 3" Thick
- No Calibration or Periodic Maintenance Required
- Independent Operation with Mains Power Supply or Built-in NiMH Rechargeable Batteries
- Detection of detonators, batteries, trigger circuits and other metal components of parcel bombs
- No alarm on metal staples, paper-clips and metal binding spirals
- Confirmation of signal (OK/ALARM) for each package inspected
- Ergonomic, compact design
- Operates on the mains power supply and with built-in NiMH rechargeable batteries
- Integrated battery charger
- No calibration or periodic maintenance required
- Optional embedded detector of radioactive materials

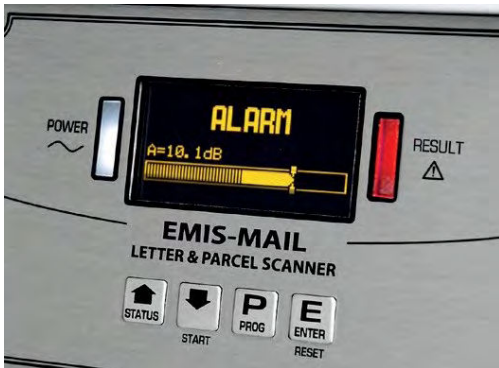

Technical Information **EMIS-MAIL**

General Characteristics

- High Inspection Speed
- No alarm on metal staples, paper-clips and metal binding spirals
- Digital programming with high-resolution OLED graphic display
- Optical and acoustic alarm signaling
- Integrated auto-diagnosis system
- Permanent memory storage of operating parameters without back-up batteries
- Independent operation, with mains power supply or incorporated batteries
- Specific Settings available for Prison parcels inspection (Dept. of Justice requirements)
- Compliant with NIJ-0602.02 Dept. of Justice Detection Requirements

Structure

- Transit opening 18" x 3"
- Degree of Protection IP40

Weight

- 35 lbs.

Power Supply

- Voltage 100-240 V~ single-phase—50/60 Hz with external AC/DC adapter
- Current 1.07 A max
- Battery Operation 6 x 1.2V NiMH size D incorporated
Battery Life: 12 hours (8 hours with IXC module)
Battery Charger incorporated: Recharging time 6 hours

Programming

- Type Local: via integrated keypad
Remote: via Bluetooth, RS232
- Data Logger Memory Capacity 10,000 events

Signaling

- Acoustic Internal Buzzer
- Optical High-contrast OLED graphic display with bar-graph indication
LED indicators on the control panel:

Security / Safety

- Access to programming protected by password
- Insulation from mains voltage

Communication

- Incorporated Bluetooth (FCC ID: Q0QWT12 - IC:5123A-BGTWT12A) interface, RS232

Environmental Data

- Temperature Operating: 14° F - 122°F
Storage: -13°F - 140°F
- Relative Humidity 5 to 90%, without condensation

Conformity*

- Safety UL61010-1 Safety requirements for electrical equipment for measurement, control and laboratory use - Part 1: General requirements
- EMC ACGIH, 2012 Threshold Limit Value (TLV) for "Sub-Radiofrequency (30 kHz and below) Magnetic Fields:
IEEE C95.1-1999: IEEE Standard for Safety Levels with Respect to Human Exposure to Radio Frequency Electromagnetic Fields, 3 kHz to 300 GHz
RPB- SC18, 1976: Recommended safety procedures for the selection, installation and use of active metal detectors, Health Canada

*Test Reports available upon request

NATO Stock Number

6665150105807

OPTIONAL

- Radiation Detection Module (Part # 67197) for detection of radioactive materials. Analysis time: 5 seconds
- IXC Module (Part # 66751) Integrated Web-server, 100base-T Ethernet, Full Speed USB interface, Wi-Fi 802.11b/g

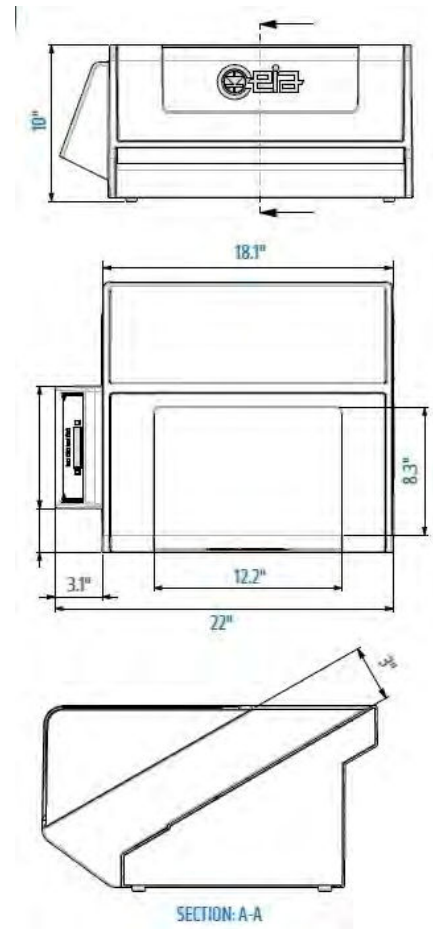

POINT SECURITY INC.
FIRST IN SECURITY SCREENING

www.pointsecurityinc.com

Point Security, Inc.
5815 NC Hwy 8 South
Lexington, NC 27292
1-800-476-1607